

eurodib

M10ETL



Easily prepare delicious recipes with our smallest planetary mixer. This compact mixer delivers high-performance mixing capabilities, effortlessly blending ingredients without sacrificing valuable kitchen space.

FEATURES

- This mixer is an essential appliance for every commercial kitchen designed to handle recipes with ease.
- Its durable stainless steel construction guarantees long-term reliability and consistent performance.
- The intuitive controls make operation simple and user-friendly.
- It offers exceptional value while ensuring quality assurance for professional results.
- This mixer is **NOT** suited for mixing bread or pizza dough.



PARTS AND
LABOR

CAPACITY CHART

Bowl size:	10.5 qt. (10 L)
Egg whites:	0.5 qt. (0.5 L)
Marshmallow:	1.1 lb (0.5 kg)
Cake batter:	7.7 lb (3.5 kg)
Cookie dough:	6 lb (2.8 kg)
Bread dough:	NOT SUITABLE
Pizza dough:	NOT SUITABLE

SPECIFICATIONS

Power:	110 V, 600 W, 6 A, 5-15P
Capacity:	10.5 qt. (10 L)
Bowl depth:	12.5" (32 cm)
Bowl diameter:	10.5" (27 cm)
Mixing speeds:	67/189/362 rpm
Max. kneading capacity:	4.4 lb/h (2 kg/h)
Dimensions:	
Length:	19.4" (49 cm)
Width:	14.9" (37 cm)
Height:	26" (66 cm)

Connection:  (110 V)

Net weight: 143 lb (65 kg)

Shipping dimensions:
Length: 40" (101 cm)
Width: 32" (81 cm)
Height: 47" (119 cm)

Shipping weight: 185 lb (83 kg)

Included accessories

- Spiral hook
- Whip
- Beater



FRONTAL VIEW

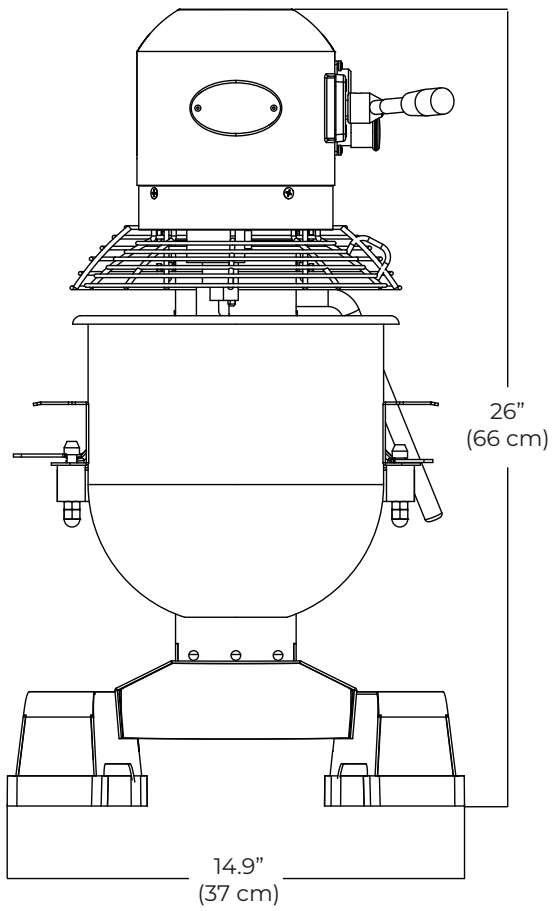

TOP VIEW

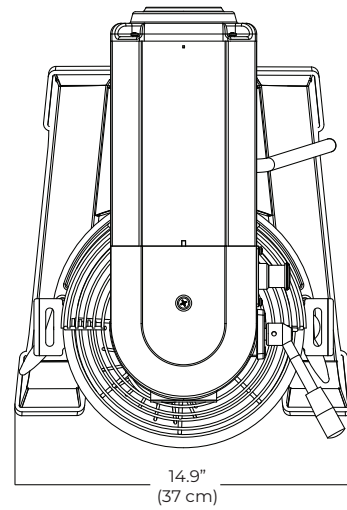

LEFT VIEW

